

### Mechanical Ventilation with Heat Recovery (MVHR)



#### PRODUCT DESCRIPTION

The PA 750LI was designed for larger homes up to 300m<sup>2</sup> in size. The unit includes an updated Visual Control with sensors to monitor Temperature, Humidity and Total Volatile Organic Compounds (TVOC) for enhanced Indoor Air Quality (IAQ).

The unit also includes a Summer Bypass as standard and has a Specific Energy Consumption (SEC) rating of A+. The system uses the Humidity & Temperature sensors to automatically control both the Summer Bypass and Boost function. The PA 750LI operates continuously at low speeds to minimise the electrical consumption (~50% running cost of conventional MVHR units) while ensuring system compliance with Part F 2019 regulations.

#### BENEFITS & FEATURES SUMMARY

- Summer Bypass as standard
- Humidity sensors controlling boost function
- TVOC (Total Volatile Organic Compounds) & Humidity sensors for improved Indoor Air Quality (IAQ)
- Touchscreen control
- Eliminates condensation, mould growth & musty odours
- Area served 300m<sup>2</sup> maximum
- Reduced running costs (~50% of conventional MVHR units)
- Compliant with current Building Regulations Part F 2019
- Expanded polyethylene casing to ensure high levels of insulation
- Low energy Electronically Commutated (EC) motor
- Remote Monitoring optional

### Technical Parameters (Product Fiche According to Commission Regulation (EU) 1254/2014)

Model PA 750LI			
Area Served (m <sup>2</sup> )	180 to 300 (max.)	Boost Switch Control	Optional
Unit Dimensions (mm)	1025 (L) x 680 (H) x 530 (D)	Sound Power Level (L <sub>WA</sub> )	63 dB @ 363 m <sup>3</sup> /h, 70 dB @ 637 m <sup>3</sup> /h
Air flow Range (l/sec)	171	Summer Bypass	Standard
Thermal Efficiency of Heat Recovery (%)	88	Duct Type	Rigid
RVU or NRVU / Unidirectional or bidirectional	RVU / bi-directional	Electrical power input of the fan drive at maximum flow rate (W)	350
Type of drive (multi-speed drive or variable speed drive)	Variable speed drive	Condensate Connection Ø	32mm
Type of Heat Recovery System (recuperative, regenerative, none)	Recuperative	Weight (KG)	27
Position and description of visual filter warning for RVUs intended for use with filters, including text pointing out the importance of regular filter changes for performance and energy efficiency of the unit	Refer to installation and maintenance instructions supplied with the unit	Maximum Flow Rate (m <sup>3</sup> /h)	615m <sup>3</sup> /h @ 100 Pa
The annual electricity consumption (AEC) (in kWh/m <sup>2</sup> /annum)	2.09	Reference Flow Rate (m <sup>3</sup> /s)	0.132
Maximum Leakage Rates (%)	External (+250 Pa): 2.3 External (-250 Pa): 2.0 Internal (+100 Pa): 2.6	Reference Pressure Difference (Pa)	50
		Specific Power Input (SPI) (W/ (m <sup>3</sup> /h))	0.31
		Control factor and control typology	0.65 and local demand

### Filter Details

Surface area (m <sup>2</sup> )	Type	Dimensions (mm)	No. of filters	-
0.18	G4 (Supply & Extract)	460 (L) x 210 (H) x 48 (D)	2	-

### Fans

Control Input	Type	Input Voltage Range (V)	No. of fans	-
MODBUS-RTU	190mm backward curve	220/230	2	-

### Controls

Protocol	Interface	Inputs	Outputs	Input Voltage (V)
Modbus	Wired touchscreen	-	-	24 DC

### Counter-Flow Heat Exchanger

Material	Surface area (m <sup>2</sup> )	No. of Plates	Plate Thickness (mm)	-
Polystyrene	34.68	50	0.4	-

### Counter-Flow Heat Exchanger

Counter-flow heat exchangers are capable of very high efficiency under correct conditions. The image in Fig. 1 shows that even at -20°C outside, the fresh air in can still be over 18°C.

Tests on the exchangers at Eindhoven University have verified the calculations. Tests on the overall system at the Building Research Establishment (BRE) in England have demonstrated that sensible efficiencies more than 90% are easily achievable.

The ProAir 750LI has the highest efficiency in its class, achieving over 88% in non-condensing conditions and achieving a specific fan power down to 0.57 W/l/s of air. In condensing conditions, (colder) this can increase to over 90%.

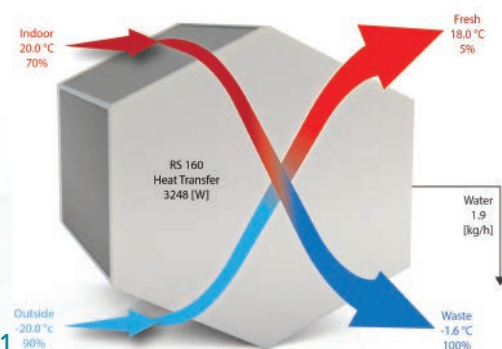

Fig. 1

### SAP PCDB Specific Fan Power (SFP)

Results with Rigid Oval Ducting DJ15 (150mm x 60mm)

Rooms	Air Flow Rate (l/s)	SFP (W/l/s)	% Efficiency
K + 1	21.0	0.58	86
K + 2	29.0	0.54	87
K + 3	37.0	0.58	88
K + 4	45.0	0.60	88
K + 5	53.0	0.66	88
K + 6	61.0	0.79	88
K + 7	69.0	0.98	87

### Specific Energy Consumption & SEC CLASS

	Cold	Average	Warm
SEC (kWh/m <sup>2</sup> /annum)	-81.89	-42.3	-17.12



### Sound Levels

Fan Speed (%)	10	15	20	25	30	35	40	45	50	55	60	65	70	75	80	85	90	95	100
dB @ 1m	37	37	37	40	43	46	50	53	56	59	61	64	67	68	69	73	72	72	72

### Main Control

The MVHR system is normally run at a speed to suit the application, which is set during commissioning. The controls will seamlessly operate according to the level of Humidity (%) and TVOC (ppb) present inside the treated envelope. The fan speeds will automatically increase as Humidity/TVOC levels rise and will return back to the commissioned set point when the level drops.

When a selected threshold of Humidity or TVOC is exceeded, the power of the system will be increased and all rooms are ventilated to the optimal condition. The fan speed will automatically increase or decrease according to the data read by the sensor.

### Summer Bypass System

The by-pass system is controlled by extract and fresh sensors reading outside and inside temperatures. When certain set points are measured, the actuator engages or disengages.

### Mechanical Dimensions

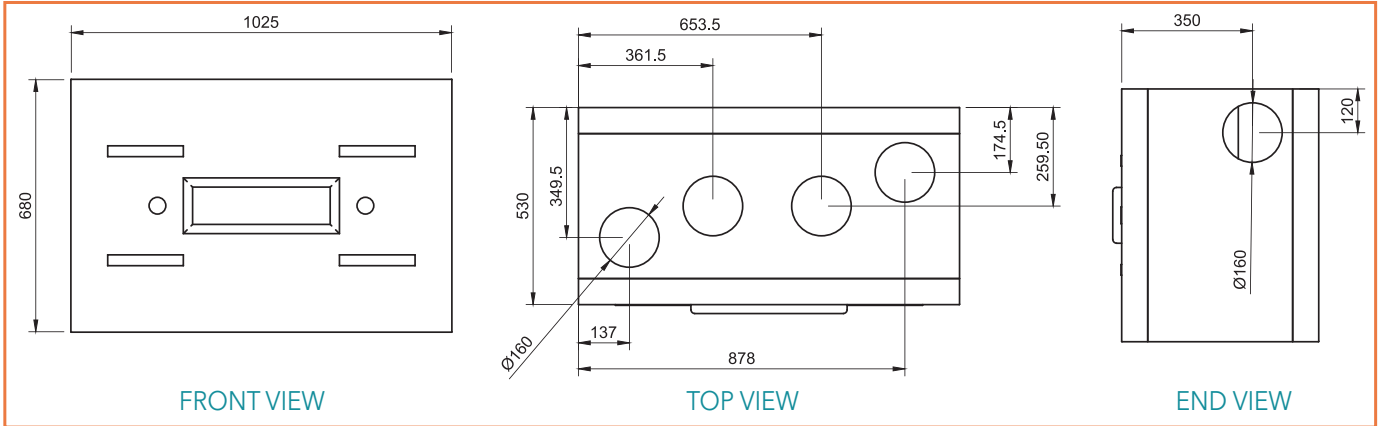

### Filters

The filters installed in this product are G4 on extract and supply side, with an option to install a higher grade relative to the application. Access to the filters is by removing access hatches that are secured with thumb screws. No tools are required to inspect or change the filters.

### Fans

The fans are high efficiency backward curved 190mm diameter with light-weight plastic impellers mounted on external rotor, electronically commutated, medium voltage, EC motors and MODBUS controlled all fitted into a customised sound absorbent dense polyethylene open-scroll enclosure. The PA 750LI has been connected to a simulated installation duct network in the ProAir test laboratory. The graph below shows the pressure drop across the fans when connected to the network

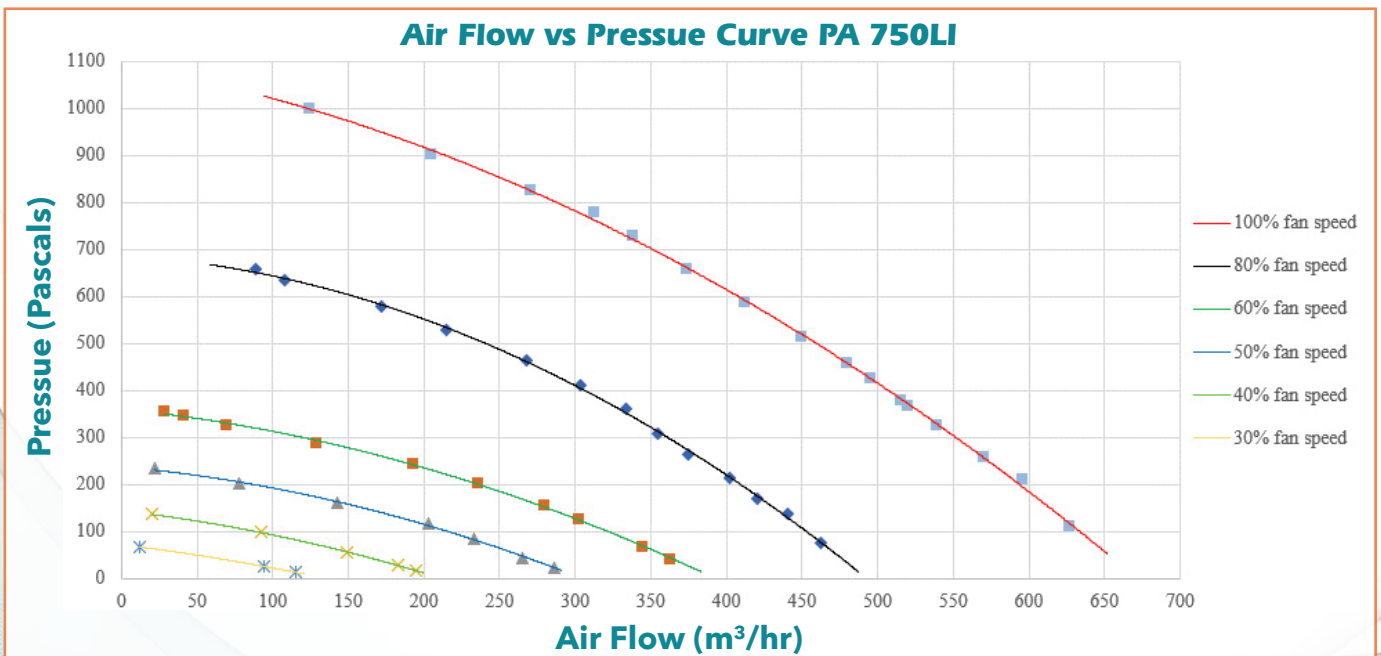

#### GALWAY OFFICE

Unit 1,  
Polkeen Industrial Estate,  
Tuam Road, Castlegar,  
Co. Galway H91 WYR8  
T 091 739 442

#### DUBLIN OFFICE

Unit P26,  
Greenogue Business Park,  
Grants Road, Rathcoole,  
Co. Dublin D24 HW44  
T 01 503 4296

#### CORK OFFICE

Foxhole Industrial Estate  
Foxhole  
Youghal  
Co. Cork P36WV79  
T 087 4178109