

### Mechanical Ventilation with Heat Recovery (MVHR)



#### PRODUCT DESCRIPTION

The PA 600LI is the flagship Heat Recovery Ventilation unit designed and developed by ProAir Systems. It was created with medium house sizes in mind. The unit can ventilate house sizes from 80m<sup>2</sup> to 210m<sup>2</sup>.

The touchscreen controller allows the homeowner to easily adjust the fan speeds and also provides filter replacement details. The PA 600LI unit is designed to operate continuously at low speeds to minimise the electrical consumption while ensuring system compliance with Part F 2019 regulations.

It has been independently tested by the Building Research Establishment (BRE) in Watford, UK and is listed on the PCDB database.

#### BENEFITS & FEATURES SUMMARY

- Heat retained in the house (Heat Recovery)
- Filtration of incoming air
- Control over incoming air flow
- Touchscreen control
- Eliminates condensation, mould growth & musty odours
- Easy installation and low maintenance
- Compliant with current Building Regulations Part F 2019
- Expanded polyethylene casing to ensure high levels of insulation
- Low energy Electronically Commutated (EC) motor

### Technical Parameters (Product Fiche According to Commission Regulation (EU) 1254/2014)

Model PA 600LI			
Area Served (m <sup>2</sup> )	80 to 210	Boost Switch Control	Yes
Power (Watts)	10 to 150	Sound Power Level (LWA)	57 dB @ 380m <sup>3</sup> /h
Unit Dimensions (mm)	1025 (L) x 675 (H) x 475 (D)	Summer Bypass	Optional
Air flow Range (l/sec)	106	Duct Type	Rigid
Heat Recovery Efficiency (%)	93	Condensate Connection Ø	32mm
RVU or NRVU / Unidirectional or bidirectional	RVU / bidirectional	Weight (KG)	25
Type of drive (multi-speed drive or variable speed drive)	Variable speed drive	Maximum Flow Rate (m <sup>3</sup> /h)	380 @ 100 Pa
Type of Heat Recovery System (recuperative, regenerative, none)	Recuperative	Reference Flow Rate (m <sup>3</sup> /s)	0.0708
Position and description of visual filter warning for RVUs intended for use with filters, including text pointing out the importance of regular filter changes for performance and energy efficiency of the unit	Refer to installation and maintenance instructions supplied with the unit	Reference Pressure Difference (Pa)	50
		Specific Power Input (SPI) (W/ (m <sup>3</sup> /h))	0.235
The annual electricity consumption (AEC) (in kWh/m <sup>2</sup> /annum)	1.13	Control factor and control typology	1 and Combination with manual switch
Maximum Leakage Rates (%)	External (±250 Pa): 2.3 Internal (+100 Pa): 2.6		

### Filter Details

Surface area (m <sup>2</sup> )	Type	Dimensions (mm)	No. of filters	-
0.26	G4 (Supply & Extract)	390 (L) x 210 (H) x 45 (D)	2	-

### Fans

Control Input	Type	Input Voltage Range (V)	No. of fans	-
Analog 0.10 / PDM	190mm backward curve	220/230	2	-

### Controls

Protocol	Interface	Inputs	Outputs	Input Voltage (V)
Modbus	Wired touchscreen	Digital 4 / Analogue 2	Fan 2 / Relay 3	24 DC

### Counter-Flow Heat Exchanger

Material	Surface area (m <sup>2</sup> )	No. of Plates	Plate Thickness (mm)	-
Polystyrene	34.68	75	0.3	-

### Counter-Flow Heat Exchanger

Counter-flow heat exchangers are capable of very high efficiency under correct conditions. The image in Fig. 1 shows that even at -20°C outside, the fresh air in can still be over 18°C.

Tests on the exchangers at Eindhoven University have verified the calculations. Tests on the overall system at the Building Research Establishment (BRE) in England have demonstrated that sensible efficiencies more than 90% are easily achievable.

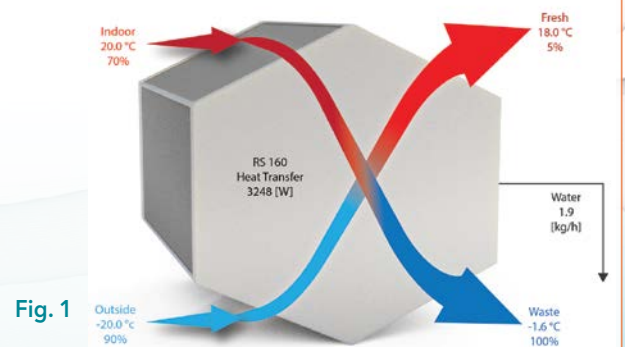

Fig. 1

### Thermal Characteristics

Recorded Temperatures (°C) @ Volumetric Air Flow Rate = 240m<sup>3</sup>/h

Indoor (1)	Waste (2)	Outdoor (3)	Fresh (4)	Heat Recovered (W)	Condensate Kg/H
20	-1.6	-20	18.0	3248	1.95
20	1.3	-15	18.2	2842	1.73
20	3.9	-10	18.5	2436	1.48
20	6.4	-5	18.7	2030	1.21
20	8.8	0	18.9	1624	0.91
20	10.9	5	19.1	1218	0.6
20	13.0	10	19.2	812	0.26
20	15.6	15	19.4	406	0.0
20	20	20	20	0.0	0.0

### SAP PCDB Specific Fan Power (SFP)

Results with Rigid Oval Ducting DJ15 (150mm x 60mm)

Rooms	Air Flow Rate (l/s)	SFP (W/l/s)	% Efficiency
K + 1	21.0	0.63	92
K + 2	29.0	0.59	92
K + 3	37.0	0.62	91
K + 4	45.0	0.65	89
K + 5	53.0	0.73	88
K + 6	61.0	0.88	88
K + 7	69.0	1.01	87

### Specific Energy Consumption & SEC CLASS

	Cold	Average	Warm
SEC (kWh/m <sup>2</sup> /annum)	-78.32	-38.79	-13.79

### Sound Levels

Fan Speed (%)	15	20	25	30	35	40	45	50	55	60	65	70	75	80	85	90	95	100
dB @ 1m	29.2	29.6	31.4	33.9	36.3	39.4	42.3	44.4	46.7	48.6	50.7	52.8	53.8	54.7	57.5	57.2	57.2	57.5

### Controls

The HRV system is normally run at a speed to suit the application, which is set during commissioning, with a facility for a timed boost over-ride. This timed boost is manually operated by means of one or more boost switches located at wet areas (shower areas). This switch line activates digital input Di1 to go to a higher speed for a pre-set time.

### ProAir Visual Pro Controller

Temperature Inputs	Analog Inputs	Digital Input	Analog Outputs
-	Ai1: CO <sub>2</sub> Sensor (Optional)	Di1: Normal boost (with pulse switch)	Ao1: Fan1 output (0-10VDC, 2-10VDC, PWM)
-	-	Di2: On/Off via fire alarm (optional)	Ao2: Fan2 output (0-10VDC, 2-10VDC, PWM)
-	-	Di3: Normal/boost via Humidistat (optional)	Ao3: Pre-heater Control
-	-	Di4: Normal/boost via PIR (optional)	-

### Mechanical Dimensions (mms)

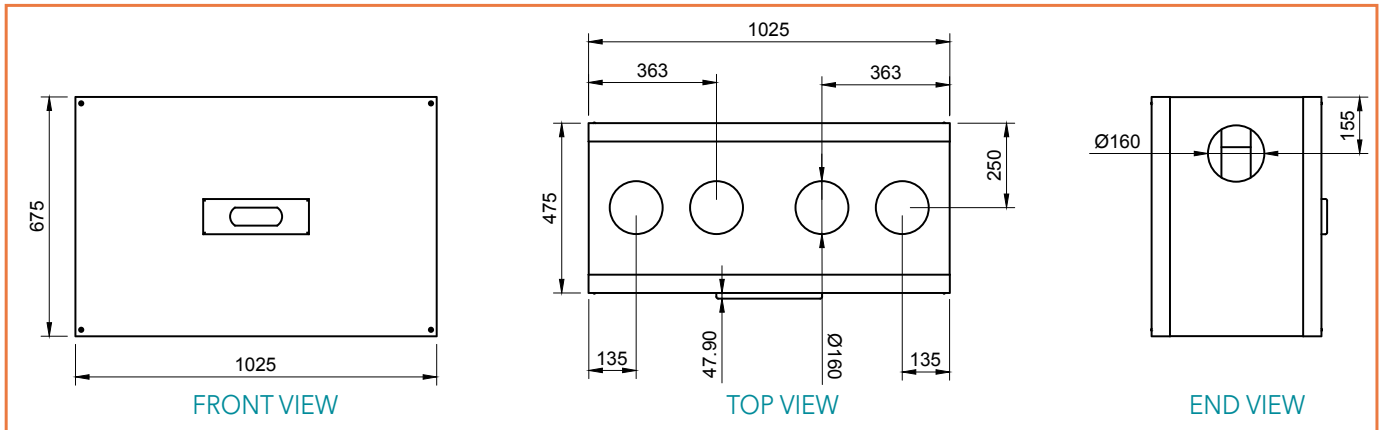

### Filters

The filters installed in this product are G4 on extract and supply side, with an option to install a higher grade relative to the application. Access to the filters is by removing access hatches that are secured with thumb screws. No tools are required to inspect or change the filters. The filters should be changed at least annually.

### Fans

The fans are high efficiency backward curved 190mm diameter light-weight plastic impellers mounted on external rotor, electronically commutated, medium voltage, EC motors, all fitted into a customised sound absorbent dense polyethylene open-scroll enclosure. The PA 600LI has been connected to a simulated installation duct network in the ProAir's test laboratory. The graph below shows the pressure drop across the fans when connected to the network.

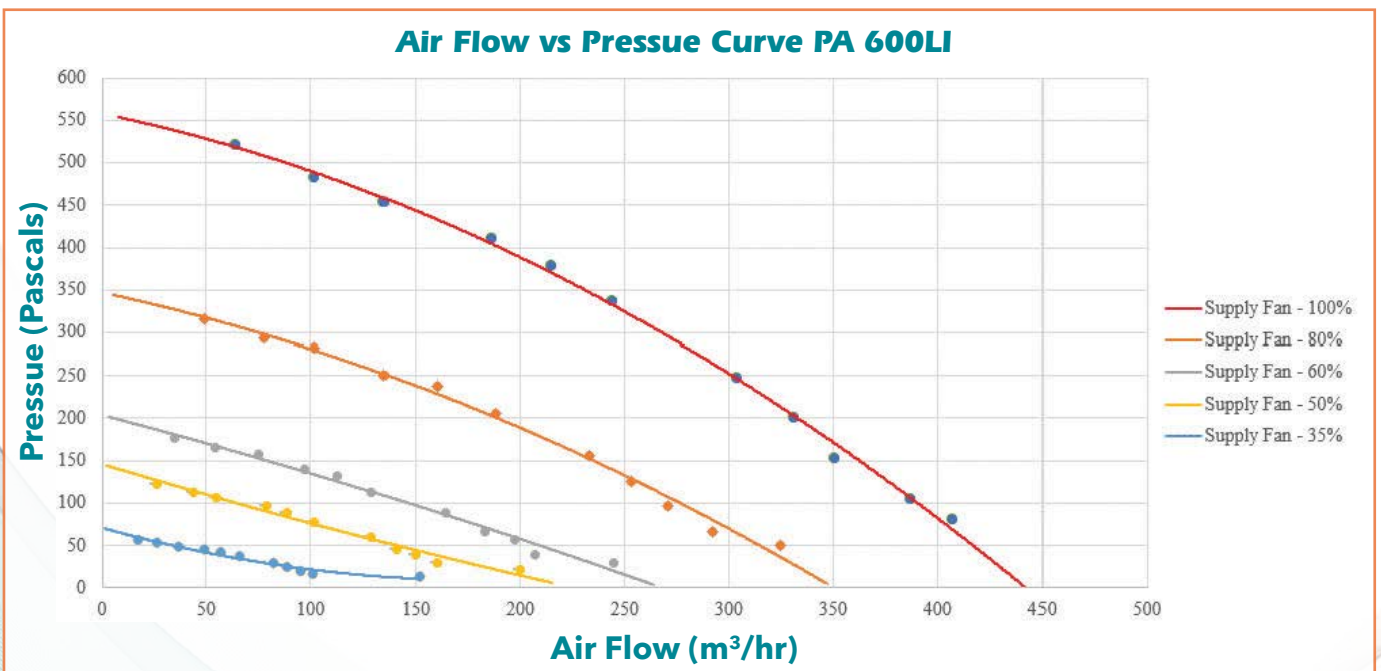

### GALWAY OFFICE

Unit 1,  
Polkeen Industrial Estate,  
Tuam Road, Castlegar,  
Co. Galway H91 WYR8  
T 091 739 442

### DUBLIN OFFICE

Unit P26,  
Greenogue Business Park,  
Grants Road, Rathcoole,  
Co. Dublin D24 HW44  
T 01 503 4296

### CORK OFFICE

Unit A11,  
Millennium Park,  
Youghal,  
Cork. P36 A522  
T 089 274 8989